

Design and Construction of a Prototype ECG Simulator

I. Valais¹, G. Koulouras², G. Fountos¹, C. Michail¹, D. Kandris² and S. Athinaios²

¹ Department of Biomedical Engineering, Technological Educational Institution of Athens, 12210 Egaleo, Athens, Greece

² Department of Electronic Engineering, Technological Educational Institute of Athens, 12210 Egaleo Athens, Greece

valais@teiath.gr

Abstract

Electrocardiographs (ECG) are medical devices that record the rhythm of the heart, particularly abnormal rhythms caused by damage to the conductive tissue that carries electrical signals, or abnormal rhythms caused by electrolyte imbalance. ElectroCardioGraph Simulators (ECGS) are devices that generate electrical signals that emulate human heart electrical signals so that the ECG recorders or monitors can be tested for reliability and important diagnostic capabilities. Modern ECG instruments with automatic wave recognition, measurement and interpretation would need for testing, a carefully selected set of test signals.

The main objective of this project is to design a practical ECGS device which can be used to perform the calibration and testing of ECG recorders. Various beat-rate or ECG rhythm (60, 80, 120, 150 and 180 bit/min) of normal ECG waveforms produced by analog electronics simulate the standard 10 electrode ECG record. Additionally a state of arrhythmia (random selection of preset ECG rhythm) is also incorporated in order to simulate abnormal ECG rhythms, which in turn should be detected accurately by the ECG recorder. The output of ECGS is monitored by an Atmel ATmega8515 microcontroller as far as the rhythm selection and the display of it, is concerned. An audible signal triggered by the R wave is also produced for easy monitoring of the pace. The produced ECG signals have been compared to human ECG recordings and the device has been calibrated accordingly in various ECG rhythms. In conclusion this ECGS device can be used as a testing device for 12 lead ECG recorders.

Key words: ECG Simulator, ECG recorder tester

Introduction

Electrocardiographs (ECGs) are medical devices that record the rhythm of the heart, particularly abnormal rhythms caused by damage to the conductive tissue that carries electrical signals, or abnormal rhythms caused by electrolyte imbalance. Physicians record ECGs easily and non-invasively by attaching small electrodes to the human body. ECGs are a standard tool used to diagnose heart disease [1].

The typical ECG waveform is shown in Figure 1. The signal is characterized by five peaks and valleys labelled with the successive letters P-Q-R-S-T [2]. Waves and complexes in the normal sinus rhythm are the P wave, PR Interval, PR Segment, QRS Complex, ST Segment, QT Interval and T wave. The P wave duration is normally less than 0.12 second and the amplitude is normally less than 0.25 mV. The duration of the QRS complex is normally 0.06 to 0.1 seconds. It is measured from the beginning of the Q wave to the end of the S wave. The QRS voltage is as small as 0.5-0.7mV. The duration of the T wave is measured from the beginning of the wave to the end. The

area encompassed by the T wave may be a little smaller or larger than that encompassed by the QRS complex [2].

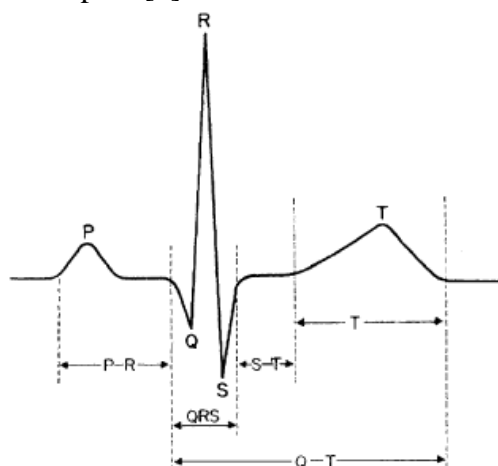

Figure 1. Basic ECG wave

Modern ECG instruments with automatic wave recognition, measurement and interpretation would need for testing, a carefully selected set of test signals [3, 4].

ElectroCardioGraph Simulators (ECGS) are devices that generate electrical signals that emulate human heart electrical signals so that the ECG recorders or monitors can be tested for reliability and important diagnostic capabilities [5].

The main objective of this project is to design a practical ECGS device which can be used to perform the calibration and testing of ECG recorders. Various beat-rates or ECG rhythm (60, 80, 120, 150 and 180 bit/min) of normal ECG waveforms produced by analogue electronics simulate the standard 10 electrode ECG record which corresponds to a 12 Lead ECG. Additionally, a state of arrhythmia (random selection of the preset ECG rhythms) is also incorporated in order to simulate abnormal ECG rhythm, which in turn should be detected accurately by the ECG recorder. The output of ECGS is monitored by an Atmel ATmega8515 microcontroller which detects the produced ECG rhythm and displays it. An audible signal triggered by the R wave is also produced for easy monitoring of the pace. The produced ECG signals have been compared to human ECG recordings and the device has been calibrated accordingly in various ECG rhythms

Materials and Methods

Circuit Design

The ECG simulator circuit design is based on an Atmel ATmega8515 microcontroller (Atmel corporation) [6].

The microcontroller main functions are a) to select the pace or rhythm of the ECG signal, b) to drive to a 2x16 LCD display, the user ECG rhythm selection and the actual ECG output rhythm and c) to trigger an audible signal of the ECG rhythm.

Figure 2 shows the three basic oscillation circuits that produce the ECG signal. The beat rate (expressed in beats per minute, bpm) is produced by the circuit shown in the bottom left corner of Figure 2. The microcontroller activates the amplifier circuit resulting to creation of a reference voltage at its output. This is driven into two self-triggered oscillation circuits (transistors TR-1 and TR-3). The voltage from the collector of the TR-1 transistor (BC327) is sent to the capacitor C6 to polarize

forward the base of the transistor TR-3 (BC327) in order to be conductive. In this way, the collector voltage of the TR-3 transistor decreases. Consequently, TR-1 is driven to cut-off through the capacitor C7. The red LED D7 lights up whenever the TR-3 transistor conducts, producing a visual signal of the ECG rhythm. This pulse sequence is then driven to the oscillation circuit comprising the transistor TR-2 and the inductor L1, shown in the right of Figure 2. This circuitry produces the P-QRS component of the ECG wave.

The heart rate pulse is driven through C2 capacitor to the base of TR-2 transistor, whereas at its collector is forming a sharp pulse. This pulse is then shaped to form the P-QRS wave using the capacitor C3 and the variable resistor (trimmer) RV1. The latter adjusts the height of the QRS peak.

The output from the TR-2 collector is also driven to a self-triggered oscillation circuitry (transistors TR-5 and TR-6) shown in the top left corner of Figure 2. In this stage the T wave of the ECG waveform is created. Resistors R18 and R19 control the amplitude of the T-wave, whereas the capacitor C9 is adjusting its width.

The three signals namely P, QRS and T are then summed through the diodes D2, D3, and D4 (1N4148) in the base of the transistor TR-4 (Figure 2 centre) where the ECG waveform is synthesized. The collector of the TR-4 is then driven through a resistor network (R24-R29) to the ECG simulator leads (RA, LA, LL, RL). The precordial leads V1-V6 can be taken at the anode of the diode D5, since these leads are considered to be unipolar (Wilson's central terminal is used for the negative electrode).

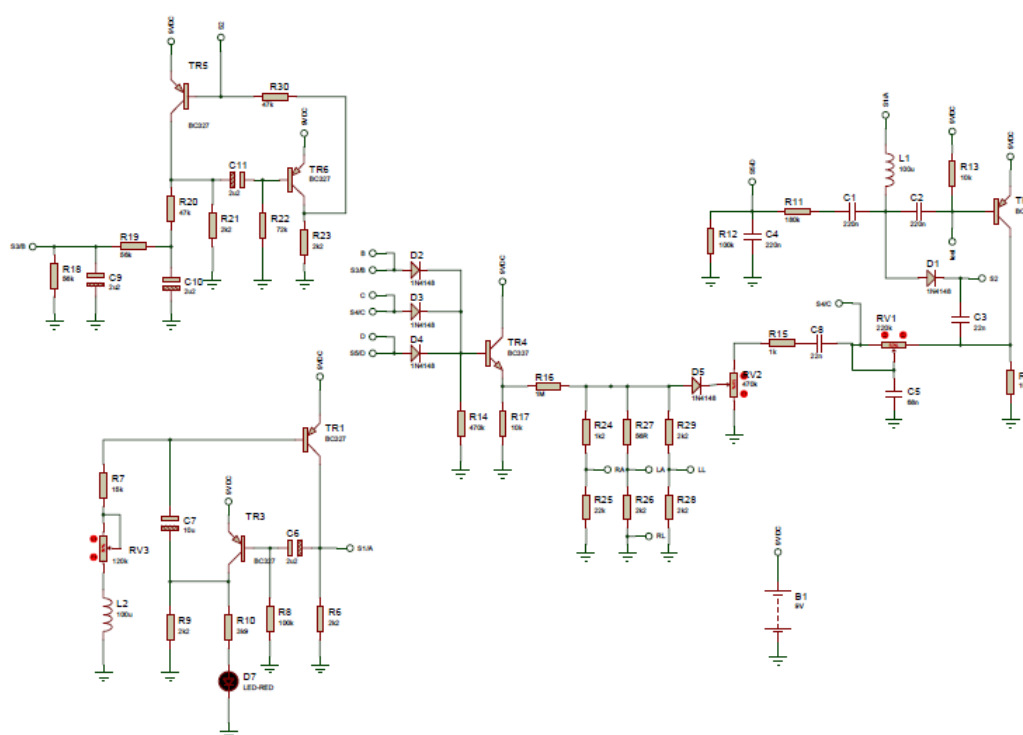

Figure 2. Schematic diagram of the ECG Simulator circuit

The TR-3 output (collector) pulse is driven to the ATmega8515 microcontroller as a TRIGGER pulse in one of its input ports (PB3) as shown in Figure 3. The pulse per

minute or heart-beats per minute are selected through the microcontroller using appropriate resistors (RES0-RES4) in five of its output ports, namely PA0-PA4. Seven output ports were used for driving the 2x16 LCD Display and one output port for driving the audible signal to a buzzer. Three push-button switches were used, two for the selection of the ECG rhythm (UP and DOWN) and one for resetting its operation and start over again. There are five rate settings, namely 60, 90, 120, 150 and 180 bpm and a setting of Arrhythmia, which is the random playback of each of the aforementioned heart rates, for two seconds. Since the resistors used for the heart rate selection are subjected to temperature drift or inaccuracies of their value, the pulse in the input port PB3 is also displayed in the LCD display, as an indication of the beat rate accuracy achieved.

The microcontroller was programmed by making use of C-programming language, CodeVision AVR compiler (CodeVisionAVR v3.06 Evaluation, HP InfoTech SRL) and STK-500 (AtmelAVR® STK500, Atmel Corporation) development system.

The apparatus is operated on a 9V battery in order to avoid any interference created by AC/DC power supply. Since the microcontroller operates in 5 Volts, a 5V voltage regulator was used for this purpose as shown in Figure 3.

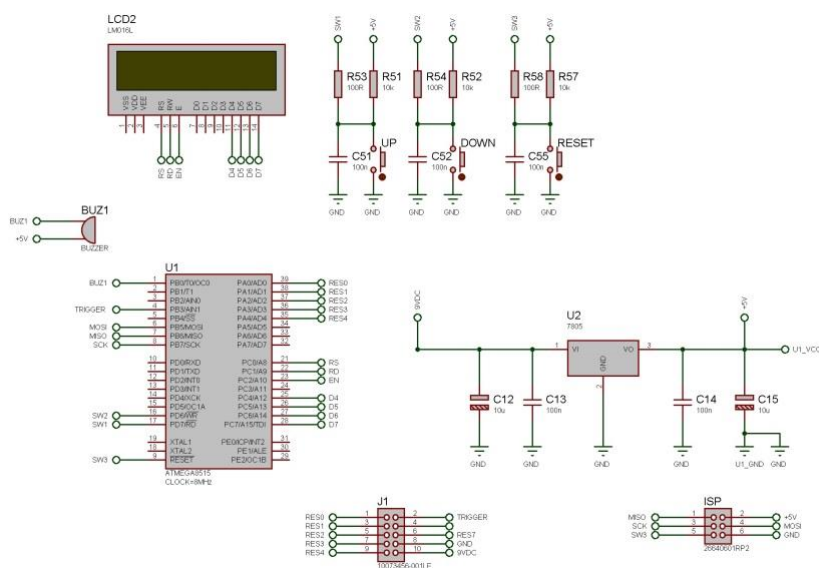

Figure 3. Schematic diagram of the Microcontroller ATmega8515 circuit

Results and Discussion

Evaluation

The ECG Simulator prototype construction is shown in Figure 4. For the evaluation of the device an ENVITEC CardiQuantWin BT3/6 ECG recorder (ENVITEC, Wismar GmbH) was used. Initially a 25 year old male human volunteer undergone ECG recording using four electrodes, namely RA, LA, LL and RL. Figure 5 shows the ECG recording for Leads I, II, III, aVR, aVL and aVF of the human volunteer.

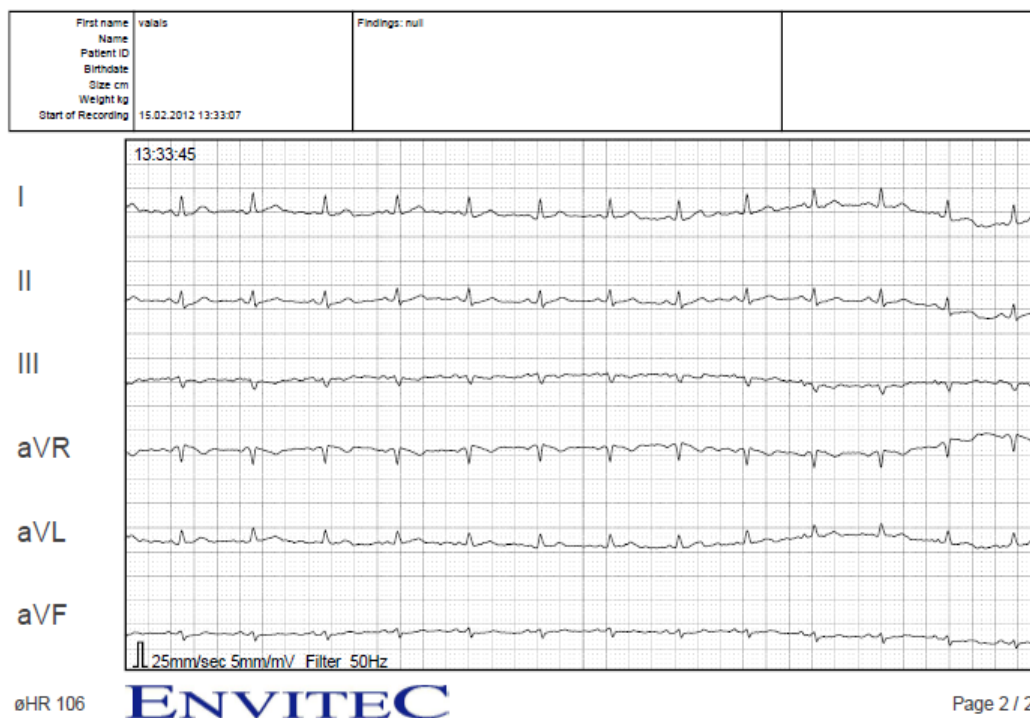
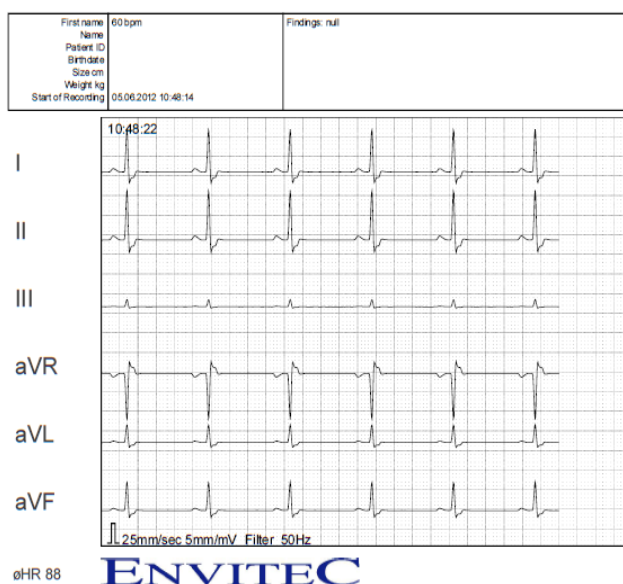
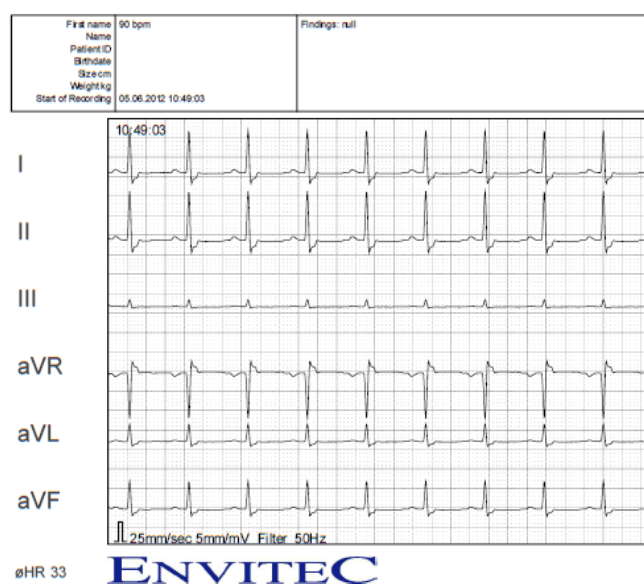

Figure 5. ECG recordings using three electrodes RA, LA and RL.

The ECG Simulator is then connected to the ECG recorder and selections of six different heart rate recordings were performed. Figure 6a and 6b show the recordings of the simulator at heart rates of 60 and 90 bpm.



(a)



(b)

Figure 6. ECG recordings using the ECG Simulator set at 60 and 90 bpm.

In portions (a) and (b) of Figure 7 the recordings of the simulator at heart rates of 120 and 150 bpm are correspondingly depicted. The observation of these two

illustrations makes evident that as the heart rate increases the interval between the R-R waves decreases. This makes more difficult to detect short arrhythmias in high heart rates.

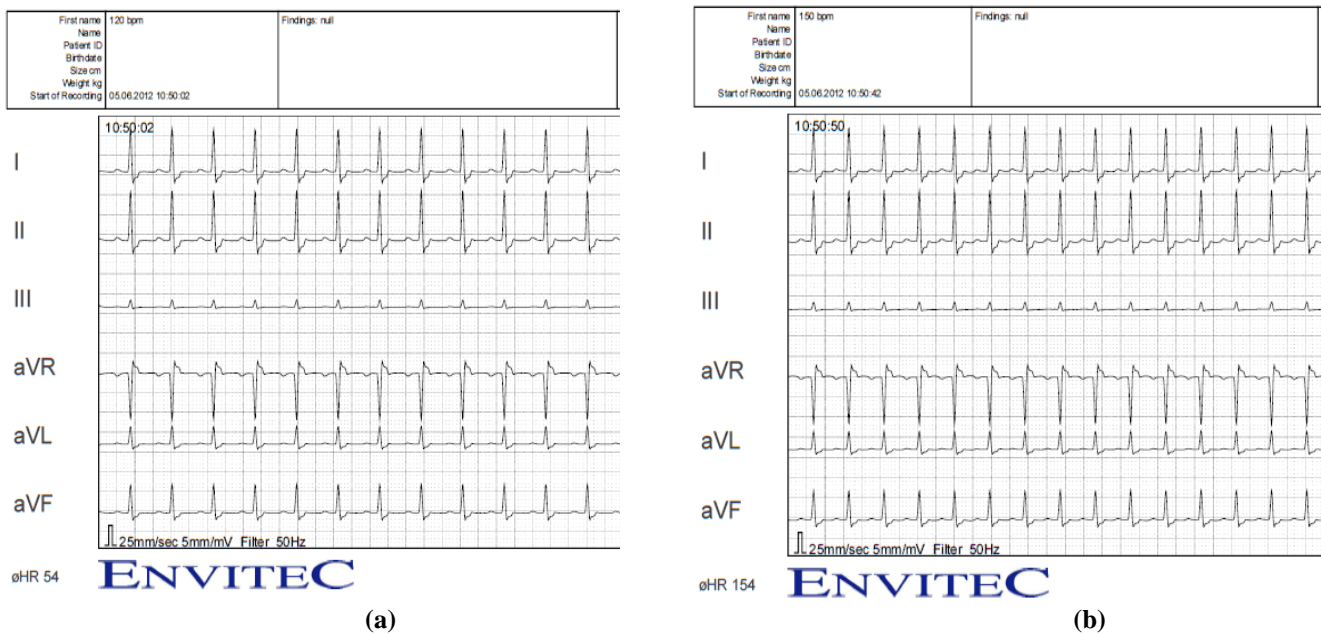

Figure 7. ECG recording using the ECG Simulator set at 120 and 150 bpm.

In portions (a) and (b) of Figure 8 the simulator recordings for heart rate 180 bpm and Arrhythmia are correspondingly illustrated. In our design, arrhythmia is implemented by randomly changing the heart rate. The microcontroller is programmed to randomly select one of the predefined heart rates for duration of two seconds and then changing randomly again. This can be seen in Figure 8(b) where the recording changes rate from 60 to 90 and then to 150 bpm.

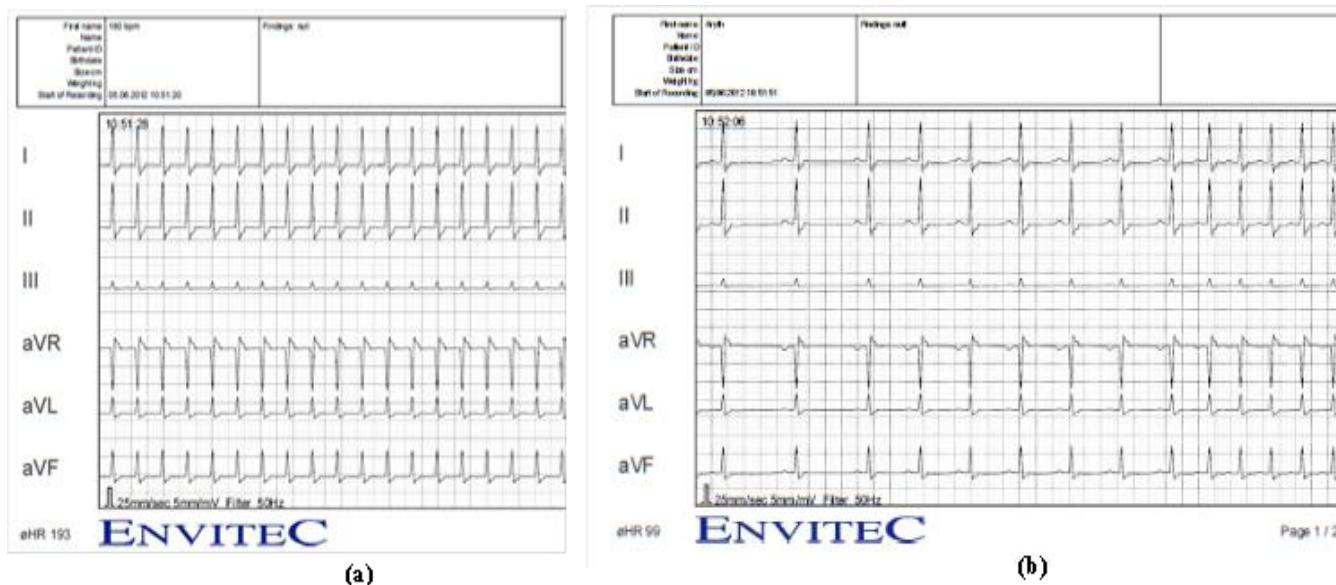

Figure 8. ECG recording using the ECG Simulator set at 180 bpm and Arrhythmia.

By comparing the human ECG recordings with the corresponding ones provided by the Simulator, as shown in Figures 5, 6, 7 and 8, a general comment can be drawn. This is that lead III and lead aVF have reverse polarity between the two recordings. This may be attributed to the polarity of either RL or LL electrodes. A further investigation on the polarity issue might correct the problem of reverse lead (III and aVF). Another finding which should be pointed out based on the recordings of the Simulator is that T-wave is much suppressed and thus difficult to be distinguished. This may be attributed to the amplification of T-wave by resistors R18 and R19. A solution to this issue might be the replacement of either of these two resistors with a variable resistor (trimmer).

Conclusion

In our study we tried to simulate human ECG waveforms of variable heart rate in order to produce a ECG recorder tester. In order to achieve this objective, analogue ECG waveform circuitry was developed, controlled by a microcontroller in order to increase the reproducibility and the stability of its output. Preliminary results indicate that our design can be used for testing ECG recorders or ECG monitors as far as their waveform detection efficiency is concerned. Moreover the built-in function of Arrhythmia gives the clinicians and the biomedical engineers the ability to test the temporal sensitivity of ECG recorders or even ECG monitors, being equipped with detection algorithms for arrhythmia prognosis.

References

1. Morris F., Edhouse J., Brady W.J., Camm J., *ABC of Clinical Electrocardiography*, BMJ Publishing Group, 2003

2. Zalis E.G., Conover M.H., *Understanding Electrocardiography: Physiological and Interpretive Concepts*, Mosby 1972.
3. Daskalov I.K, Dotsinsky I.A, Christov I.I. “Developments in ECG acquisition, preprocessing, parameter measurement and recording”. *IEEE Eng in Med and Biol* 1998;17:50–8.
4. Willems J.L, Arnaud P, Van Bommel J.H, Degani R, Macfarlane P.W, Zywiets C. “Common standards for quantitative electrocardiography: goals and main results”. *Methods of Information in Medicine* 1990;29:263–71.
5. Webster J. G., *Medical Instrumentation Application and Design*, Third ed., John Wiley & Sons, 1998
6. ATMEGA8515 Datasheet (PDF) - ATMEL Corporation - 8-bit AVR Microcontroller with 8K Bytes In-System Programmable Flash, available in: <http://www.atmel.com/devices/atmega8515.aspx>